

## MONFLOW

### 單流式

For the through flow application, rotary joints are installed on both ends of the roll. Fluid enters from one end and is discharged through the other. An internal pipe is not needed.

在滾輪的兩端裝置旋轉接頭屬貫流方式，流體由一端進入而由另端排出，不需要內管裝置。

Fig.1

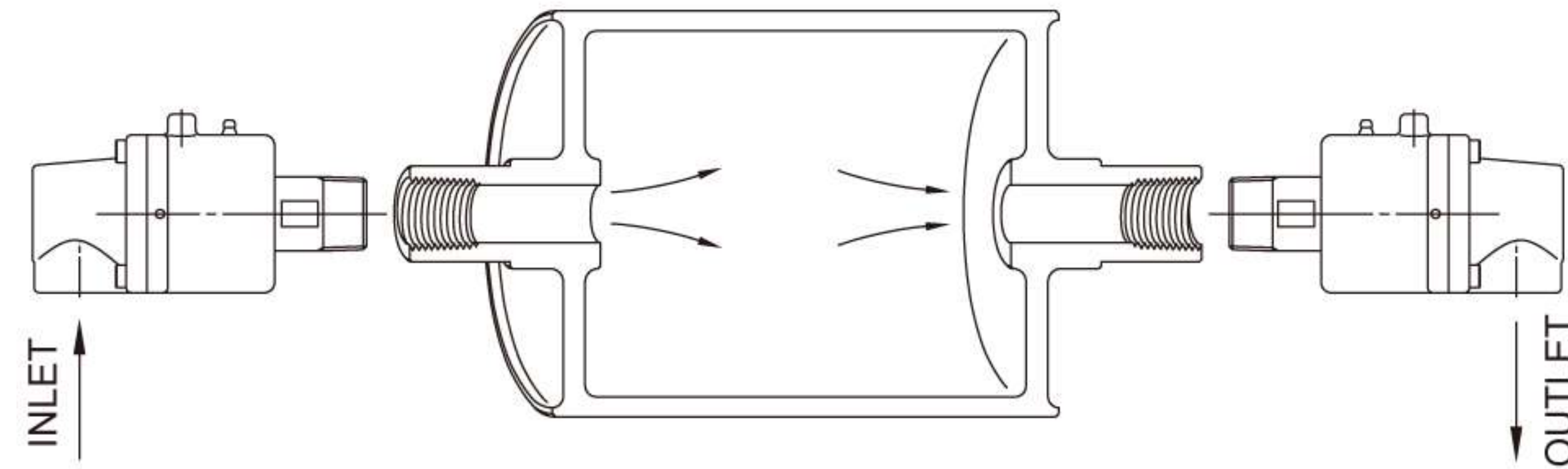

## DUOFLOW FIXED INTERNAL PIPE

### 複流式（內管固定）

A rotary joint is only installed on one end. Fluid enters through an internal pipe. Fluid is discharged from the same end.

在滾輪的一端裝置旋轉接頭，同時在此端能有流體的進入及排出之功能。

Fig.2

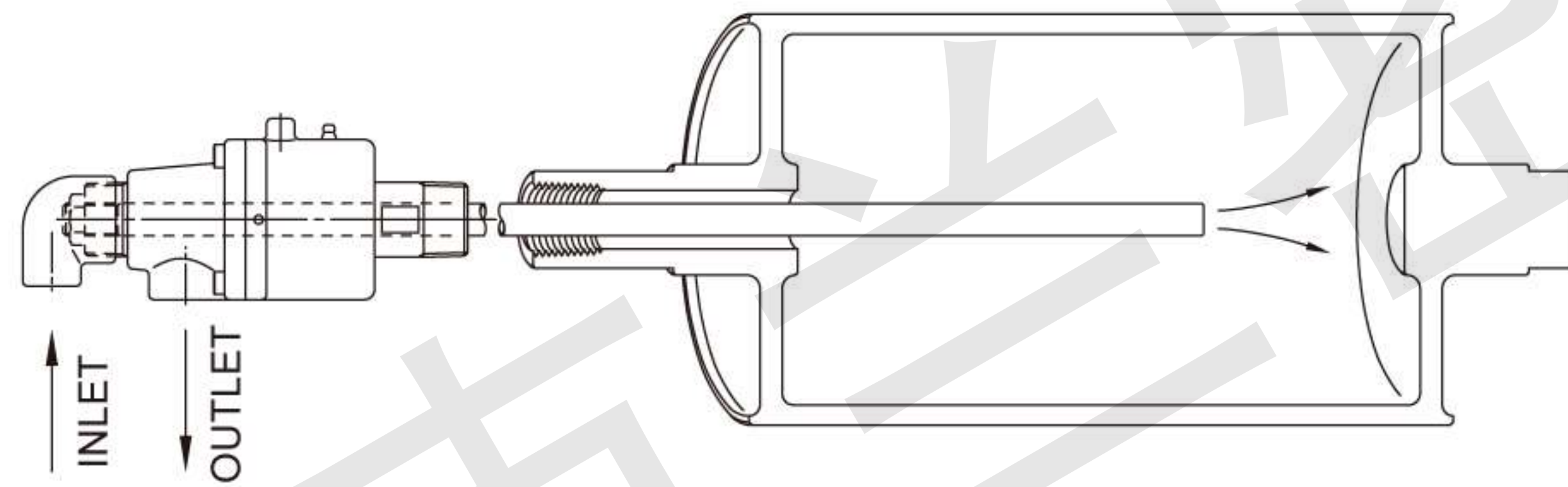

## DUOFLOW FIXED INTERNAL PIPE ( SYPHON )

### 複流式（內管固定）

This model is different in that a syphon is installed inside for discharge of condensate. It's most suitable for steam systems.

此型不同處為滾輪內設有虹吸管，將冷凝水排出，此型多用於蒸氣。

Fig.3

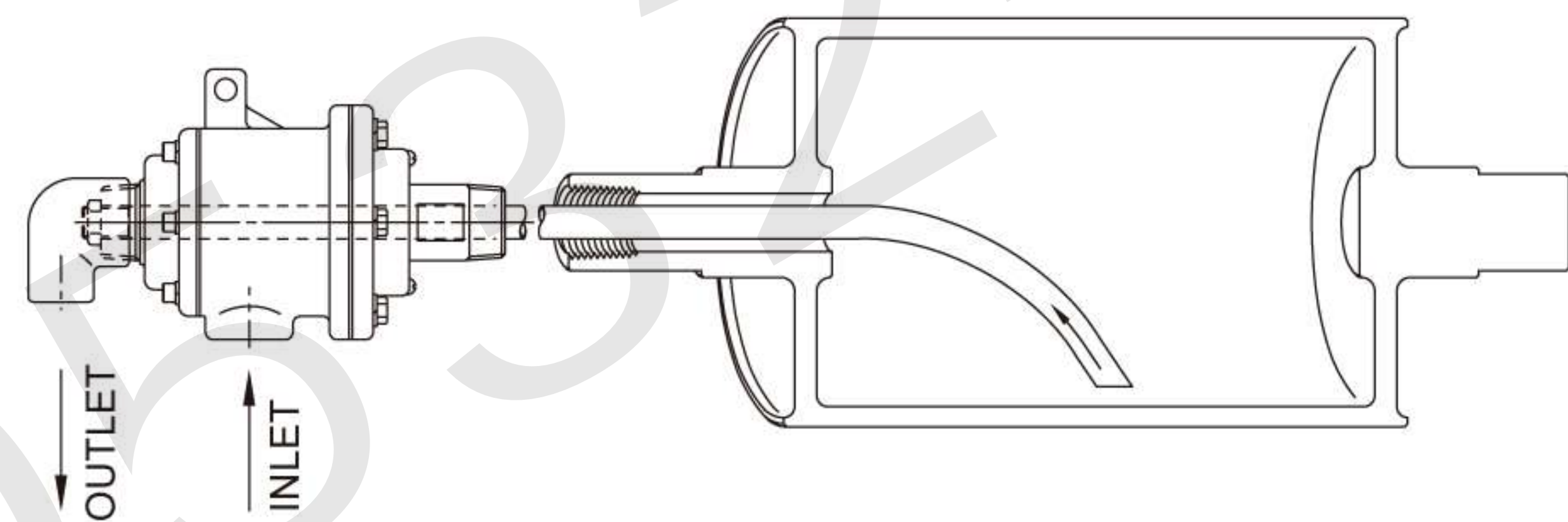

## DUOFLOW ROTATING INTERNAL PIPE

### 複流式（內管旋轉）

This type has a rotary joint at one end with an internal pipe. The pipe and fluid flow tube fit together tightly to prevent fluid from leaking back, thus ensuring heating & cooling efficiency. The internal pipe rotates in conjunction with the roll.

此型為內管與滾輪的中心流體通孔做緊密的連接，以免流體回流而影響滾輪之升降溫效率，內管與滾輪同步運轉。

Fig.4

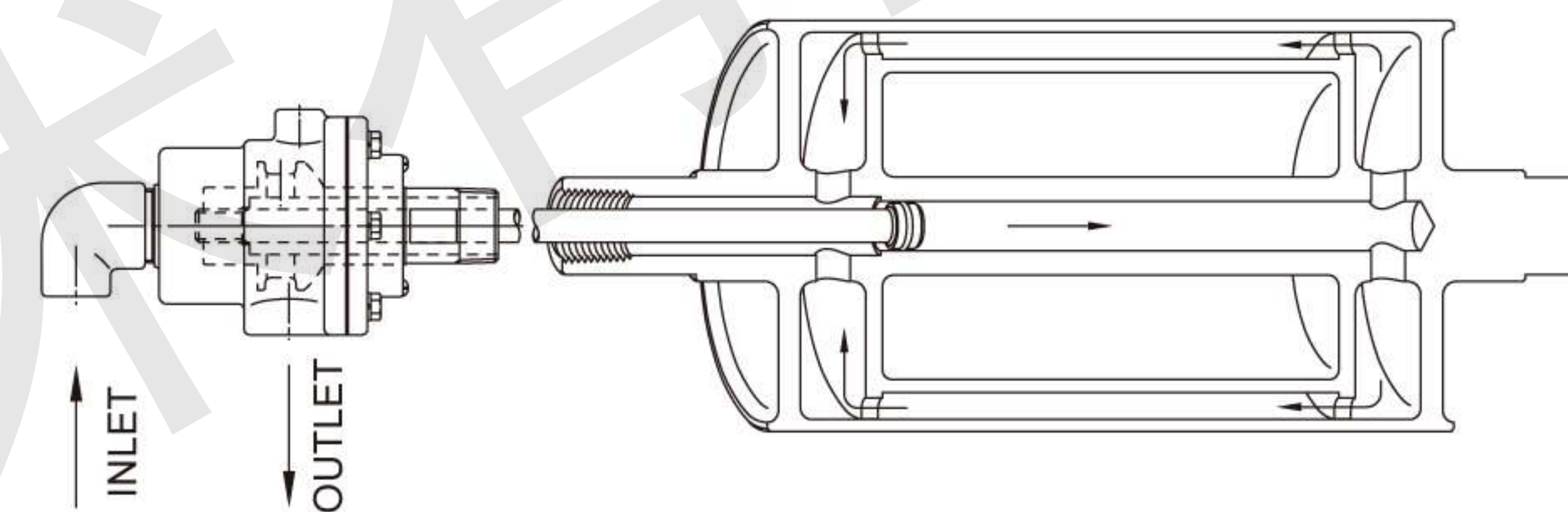

## DUOFLOW ROTATING INTERNAL PIPE ( SYPHON )

### 複流式（內管旋轉）

The rotary syphon fits tightly into the dryer. While the dryer is rotating, the condensation is pulled by centrifugal force to the outside edges. It is collected and discharged by the syphon, rotating in conjunction with the dryer.

在滾輪的內側裝置一套與內壁貼觸的旋轉式虹吸管，當滾輪轉動時內部的虹吸裝置與滾輪同步運轉，冷凝水由集水口排出。

Fig.5

